

REV	DESCRIPTION	DRAWN	DATE

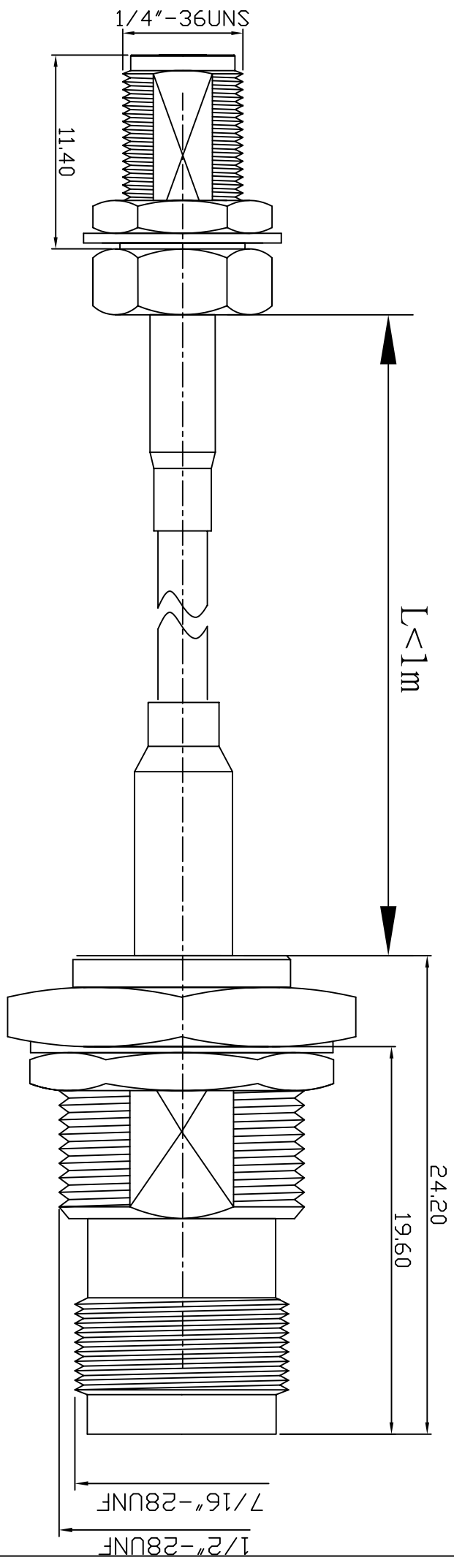

NO	Description	Qty	Material	Finish
3	TNC-1514-11-F-TGN	1	BRASS	NICKEL
2	LLC200/RG58	1		
1	SMA-1012-33-F2-TGG	1	BRASS	GOLD

UNLESS OTHERWISE SPECIFIED
 1 REMOVE ALL BURRS
 2 BREAK ALL CORNERS & EDGES CO.15 MAX.
 3 CHAMFER 15° & LAST THREADS 45°.
 4 DIAMETERS ON COMMON CENTERS
 5 ALL DIMENSIONS ARE AFTER PLATING.

*MAJOR DIMENSION
 UNLESS OTHERWISE NOTED TOLERANCES
 0.5-6=±0.2
 6-30=±0.4
 30-120=±0.6
 120-315=±1.0
 ANGLES=±1°

APPROVED	CHECKED	DRAWN	DRAWN DATE
		ARNO	03/06/21

華耀科技有限公司
 Hua Yao Technologies co.,Ltd
 TITLE SMA1012-TNC1511
 DRAWING NO. 101233/200/58/151411-IL
 FILE NO. D:\DWG\SMA1012-TNC1511\101233/200/58/151411-IL
 REV A